

# SWEPAC

FB 430

FB 450

FB 500

FB 510

---

## USER MANUAL IN ORIGINAL

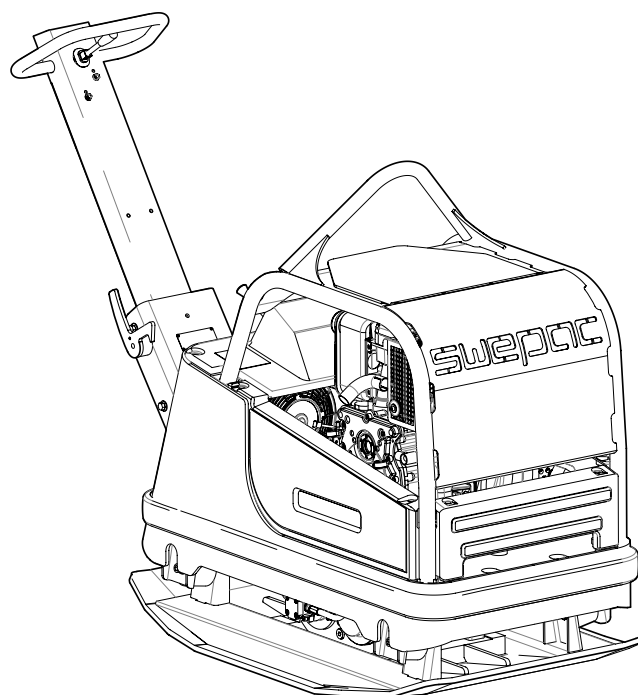
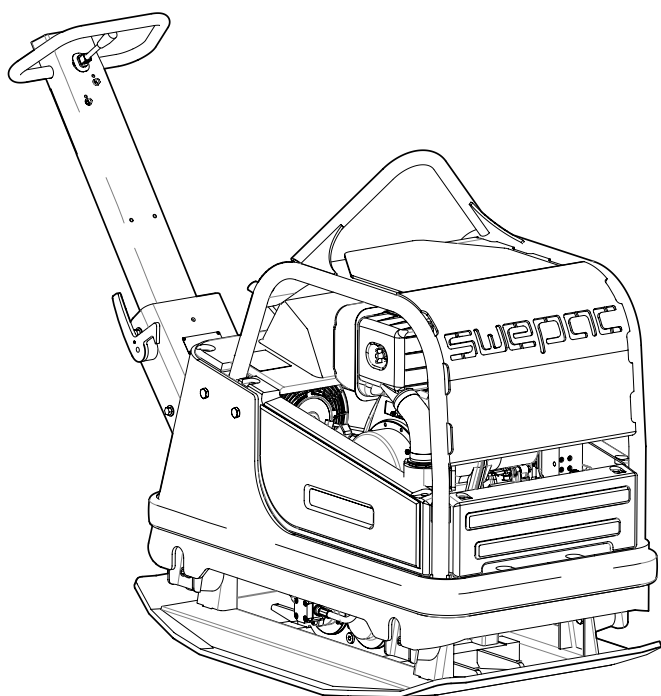



## USE

### **SWEPAC FB430 / FB 450 / FB500 / FB 510**

are used to pack ballast under foundations, in connection with road building, in trenches, etc. On account of the forward/reverse function, the machine is very suitable for packing in tight spaces and as a complement to larger packing equipment. The infinitely variable speed control makes it possible to move with great precision and to pack without moving.

---

## CONTENTS

USE .....	3
SAFETY INSTRUCTIONS .....	4
STANDARDS .....	4
SIGNS .....	5
TECNICAL DATA.....	6
METHOD OF OPERATION .....	6
TECHNICAL DESCRIPTION .....	7
DAILY CHECKS.....	8; 9
BEFORE STARTING .....	10
STARTING, <b>Yanmar</b> .....	10
STOPPING .....	10
BEFORE STARTING.....	11
STARTING, <b>Hatz</b> .....	11
STOPPING.....	11
OPERATING INSTRUCTIONS .....	12
TRANSPORTATION .....	12
BELT TENSION / REPLACEMENT OF THE BELT.....	13; 14
MEASURING AND ADJUSTMENT THE HYDRAULIC PRESSURE FB 450 / FB 510.....	15
HYDRAULIC DIAGRAMM 450 / FB 510.....	16
MEASURING AND ADJUSTMENT THE HYDRAULIC PRESSURE FB 430 / FB 500.....	17
HYDRAULIC DIAGRAMM 430 / FB 500.....	17
COMPACTION INDICATOR (SCI).....	18
EC-DECLARATION OF CONFORMITY.....	19

**SAFETY INSTRUCTIONS**

- Before using the machine, the operator must be informed of the manufacturer’s safety instructions and instructions for use.
- The machine may only be used outdoors.
- The machine may not be used if protection and safety devices are not present or not working.
- The operator may not leave the machine unattended when the engine is on. When the vibrator is connected, the operator must be able to control the movement of the machine using the control handle and the start/stop controls. The machine may be operated only by a trained operator.
- During maintenance work or other interventions in the machine, the engine must always be off.
- Switch the engine off before adding fuel. Avoid fuel spillage and immediately wipe off any spilled fuel. Add fuel only in well ventilated areas.
- Avoid touching hot engine parts, for example the silencer.
- Before lifting the machine, check that the lifting device and its mounting are not damaged and that the rubber dampers on the base plate are undamaged and tightened.
- During transportation and storage, the fuel tank should be empty and the fuel cock switched off.
- When the machine is parked, ensure that it cannot tip over. The machine may not incline more than 20°.
- The operator must use ear protectors when working with the machine.
- The operator must ensure that no unauthorised persons are in the immediate vicinity of the machine.
- Always wear personal protective equipment as heavy, non-slip shoes, ear protectors and approved eye protection.
- The machine may not be used in environments in with potential fire or explosion danger.
- Never use the machine if you are tired or have consumed alcohol or are under medication that could affect your vision, your discretion or your coordination ability.
- Never use a machine in any way changed from the original design.

**STANDARDS**

**Noise**

Measurement in accordance with the standard EN 500-4 Rev. 1:1998, Annex C:

Measurement uncertainty ± 0.5 dB (A) in 95% of the measurements.

In accordance with the conditions in Directive 2000/14/EC, Annex VI, the following values are reported:

	<b>FB 430</b>	<b>FB 450</b>	<b>FB 500</b>	<b>FB 510</b>
Sound pressure level at the operator’s ears, L <sub>pA</sub>	93 dB (A)	93 dB (A)	93 dB (A)	93 dB (A)
Permitted sound power level, L <sub>WA</sub>	108 dB (A)	108 dB (A)	108 dB (A)	108 dB (A)
Guaranteed sound power level, L <sub>WA</sub>	108 dB (A)	108 dB (A)	108 dB (A)	108 dB (A)

As the sound pressure level at the operator’s ears exceeds 80 dB (A), ear protectors must be used during operation!

**Hand/arm vibrations**

The vibration acceleration was measured in accordance with the ISO 5349 standard during operation on a surface of macadam. The measurement values were translated into the maximum daily exposure time for regular usage. For additional information about vibrations, please confer the regulation AFS 2005:15 from the Swedish Work Environment Authority, effective July 1st 2005.

Measurement uncertainty ± 0.3 m/s<sup>2</sup> in 95% of the measurements

	<b>FB 430</b>	<b>FB 450</b>	<b>FB 500</b>	<b>FB 510</b>
Hand/arm vibrations, m/s <sup>2</sup>	2,9	2,6	2,9	2,6
The maximum daily exposure time	5,95 h	7,4 h	5,95 h	7,4 h

**Exhaust Emissions**

The FB 430 / FB 450 / FB 500 / FB 510 meets the requirements for exhaust emissions in accordance with US-EPA stage 2.

## SIGNS

### Warning Signs

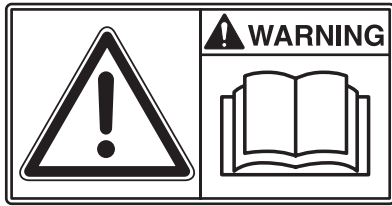

Before use, carefully read the manual and its safety instructions so that you can handle the machine safely. Ensure that the manual is always accessible.



Engine, silencer: to avoid burns or discomfort, do not touch hot engine parts when the engine is on or when the machine has recently been used.



### Only FB 430 and FB 500

Belt drive: Keep hands, tools and other objects away from the belt drive when the machine is on to avoid injury and damage. See the safety instructions in the manual.



As the sound pressure level at the operator's ears exceeds 80 dB (A), ear protectors must be used when working with the machine to prevent hearing damage.

### Machine Signs

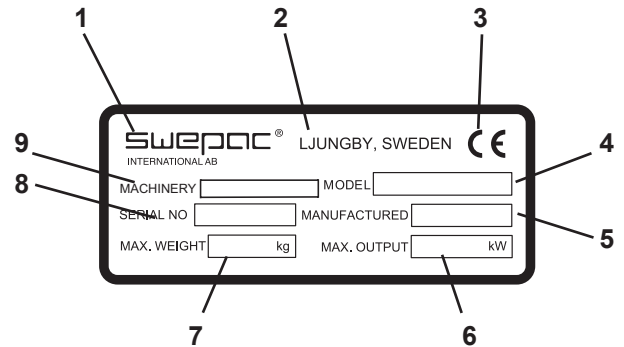

1. Manufacturer
2. Place, country of manufacture.
3. CE mark.
4. Model name.
5. Year of manufacture.
6. Max. engine power.
7. Max. weight.
8. Serial number.
9. Machine type

**TECHNICAL DATA**

**FB 430**

Net weight.....	430 kg
Base plate, w x l.....	700 x 1080 mm
Speed.....	approximately 25 m/min
Permitted inclination .....	20°
Centrifugal force .....	66,000 N
Vibration frequency .....	70 Hz
Drive engine.....	Yanmar L 100N
Engine power .....	7 kW
Engine RPM.....	3000 RPM
Fuel tank volume.....	5.5 liter
Fuel type.....	Diesel
Hydraulic oil quantity.....	1,6 liter
Battery capacity .....	40 Ah
Generator power.....	180 W (15 A)

**FB 450**

Net weight.....	445 kg
Base plate, w x l.....	700 x 1080 mm
Speed.....	approximately 25 m/min
Permitted inclination .....	20°
Centrifugal force .....	60,000 N
Vibration frequency .....	72 Hz
Drive engine.....	Yanmar L 100N
Engine power .....	7 kW
Engine RPM.....	3000 RPM
Fuel tank volume.....	5.5 liter
Fuel type.....	Diesel
Hydraulic oil quantity.....	13 liter
Battery capacity .....	40 Ah
Generator power.....	180 W (15 A)

**FB 500**

Net weight.....	490 kg
Base plate, w x l.....	700 x 1080 mm
Speed.....	approximately 25 m/min
Permitted inclination .....	20°
Centrifugal force .....	66,000 N
Vibration frequency .....	72 Hz
Drive engine.....	Hatz 1D50Z
Engine power .....	7.5 kW
Engine RPM.....	3000 RPM
Fuel tank volume.....	5.5 liter
Fuel type.....	Diesel
Hydraulic oil quantity.....	1,6 liter
Battery capacity .....	40 Ah
Generator power.....	180 W (15 A)

**FB 510**

Net weight.....	500 kg
Base plate, w x l.....	700 x 1080 mm
Speed.....	approximately 25 m/min
Permitted inclination .....	20°
Centrifugal force .....	66,000 N
Vibration frequency .....	72 Hz
Drive engine.....	Hatz 1D50Z
Engine power .....	7.5 kW
Engine RPM.....	3000 RPM
Fuel tank volume.....	5.5 liter
Fuel type.....	Diesel
Hydraulic oil quantity.....	13 liter
Battery capacity .....	40 Ah
Generator power.....	180 W (15 A)

**METHOD OF OPERATION FB 450 / FB 510**

The machine consists of a base plate with a vibration element and an upper part cushioned from the base plate. The cushioning between the base plate and the upper part consists of four rubber dampers. The upper part, on which the drive engine is mounted, is also designed as a hydraulic oil tank. The control handle is placed on the upper part and cushioned with rubber dampers. The vibration element is driven and the direction of travel is changed by means of hydraulics. The hydraulic pump, mounted on the diesel engine, supplies a hydraulic motor on the vibration element with an oil flow. The vibration element consist of two shafts on roller bearings with bias weights that are connected to gear wheels that rotate in opposite directions. One gear wheel can rotate on its shaft by means of a hydraulic cylinder. This changes the mutual phase positions of the eccentric weights and the direction of travel of the machine, and the speed is changed infinitely variably. The engine is well protected against damage in connection with use and transportation by a sturdy protective frame with a protective panel.

**METHOD OF OPERATION FB 430 / FB 500**

The machine consists of a base plate with a vibration element and an upper part cushioned from the base plate. The cushioning between the base plate and the upper part consists of rubber dampers. The power is transmitted from the engine to the vibration element via a V-belt which can be adjusted with a belt tensioner. The engine V-belt pulley is fitted with an integrated centrifugal clutch, which allows the engine to be started and run idle without the vibrator being connected. The engine is well protected against damage in connection with use and transportation by a sturdy protective frame with a protective panel.

**FUEL and OIL RECOMMENDATIONS**

Fuel .....	Diesel
Engine oil .....	SAE10W-30
Oil quantity, crankcase.....	1,5 liter
Engine oil change diesel engine: first oil change after 50 hours then every 200 hours of operation. Replace the filter when you change oil.	
Hydraulic oil type / quantity FB450 / FB510.....	HydraWay BIO SE 32-68.....13 liter
Hydraulic oil type / quantity FB500.....	HydraWay BIO SE 32-68.....1,65 liter
Replace hydraulic oil filter.....	after 3 years
Oil type/quantity, vibration unit.....	SAE10W-30.....0,5 liter

**TECHNICAL DESCRIPTION**

**FB 450 / FB 500 / FB 510**

**Left side view**

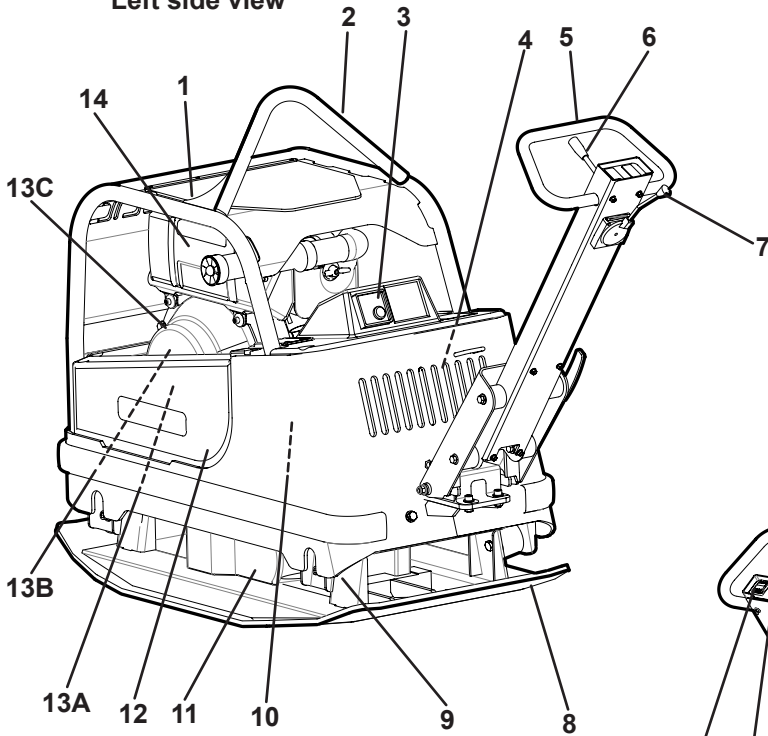

**Right side view**

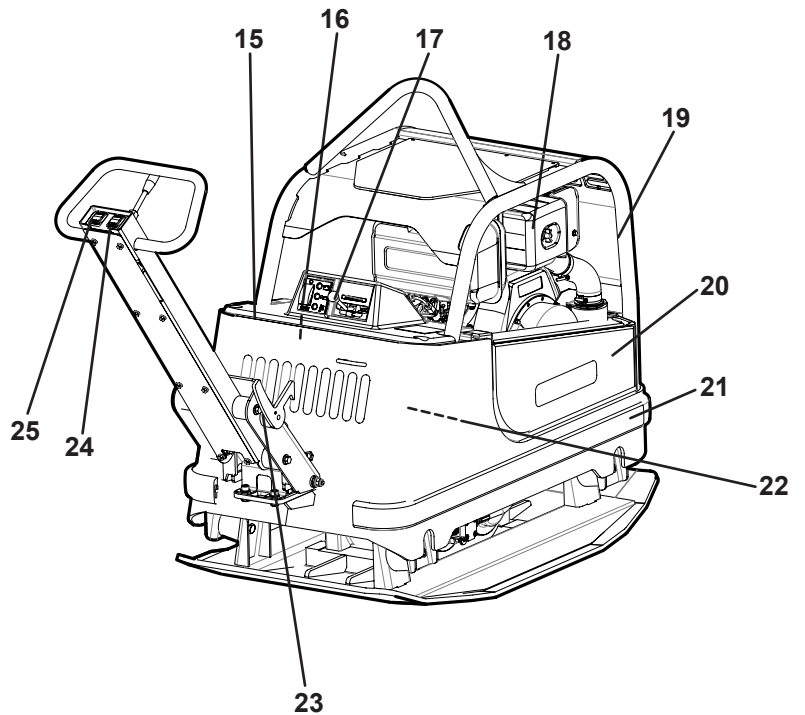

**Left side view**

- 1. Cover
- 2. Lifting eye
- 3. Control panel
- 4. Hydraulic tank
- 5. Control handle
- 6. Forward/reverse control
- 7. Throttle
- 8. Base plate
- 9. Rubber damper
- 10. Battery
- 11. Vibration element
- 12. Protective lock, left side
- 13A. Hydraulic pump FB450 / FB510
- 13B. Centrifugal clutch FB430 / FB500
- 13C. Belt guard FB430 / FB500
- 14. Engine

**Right side view**

- 15. Battery cover
- 16. Hydraulic oil filter FB450 / FB510
- 17. Throttle lever FB450 / FB510
- 18. Air filter
- 19. Protective frame
- 20. Protective lock, left side
- 21. Protective list
- 22. Hydraulic oil cooler FB450 / FB510
- 23. Transport locking device
- 24. Handle heating switch FB450 / FB510
- 25. Switch start and stop the vibrator

## DAILY CHECKS

### Fuel Check

Check that there is fuel in the tank. Top up if necessary.

### Engine Oil Level Check

Check the oil level in the crankcase every day. Turn off the engine. The machine is on a level surface.

**FB430 / FB 450:** The oil must reach the edge of the filling hole.

**FB 500 / FB 510:** The oil must reach up to the "MAX" marking.

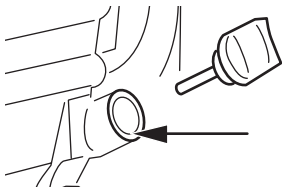

FB 430 / FB 450

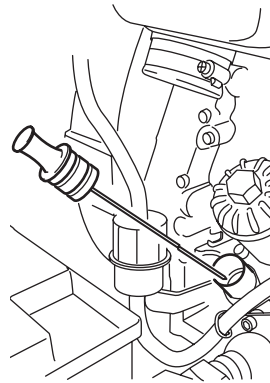

FB 500 / FB 510

### Oil/Fuel Leakage

Check every day that the engine is not leaking oil or fuel. If a leak is discovered, the machine may not be operated until the fault has been remedied.

### Air Filter Check

The air filter must be checked at least once every working week. When working in dusty conditions, check daily.

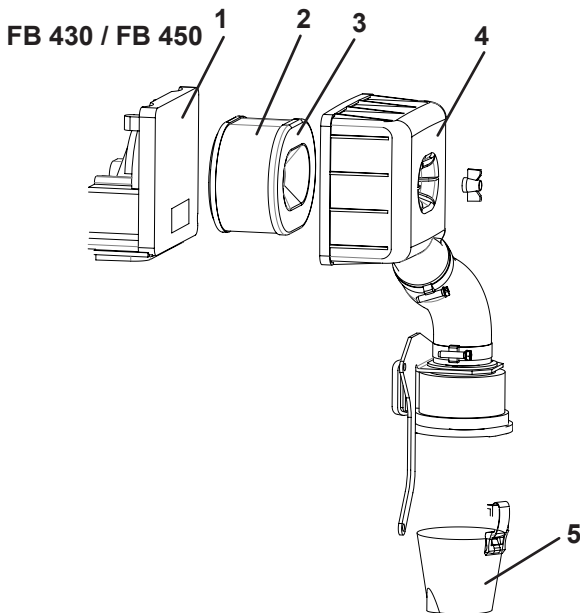

1. Filter plate
2. Foam plastic element
3. Paper element
4. Filter cover
5. Cyclone filter collector

### Cleaning

1. Remove the foam plastic element and the paper element and check that they are undamaged. Replace damaged parts.
2. Wash the foam plastic element in liquid with a high flashpoint and let it dry properly. Dip in engine oil and squeeze dry.
3. Strike the paper element against a hard object a few times to loosen any dirt.
4. Check that the filter plate is clean. Clear the cyclone filter collector.

FB 500 / FB 510

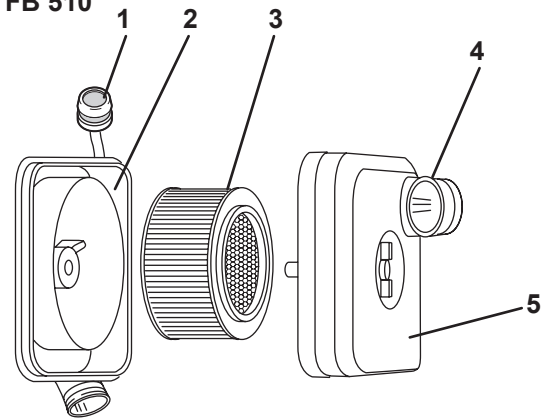

1. Indicator
2. Filter plate
3. Filter
4. Air intake with cyclone
5. Filter cover

### Cleaning

With the engine at full RPM, press in the indicator (1) for the air filter. If it remains depressed, clean the filter as described below. This may need to be done several times a day in dusty conditions.

1. Loosen the wing screw in the filter cap (5). Check that the dust outlet (4) is not clogged. Clean it if necessary.
2. Loosen the filter (3) and blow it clean with dry compressed air, max. 5 bar, from the inside until no more dust comes out. Replace a damaged filter.
3. Check that the filter plate (2) in the filter housing is clean.



### Hydraulic Oil Level Check FB 450 / FB 510

Check every day that the hydraulic connections do not leak or wear during operation. The oil level in the tank must be according the picture, max. 4 cm below from the top of the tank. Fill up hydraulic oil as described below.

Remove the battery cover. Remove the tank cover (1). Remove the filter (2). Fill up hydraulic oil and reassemble filter and cover. The cover must be well tightened when reassembling.

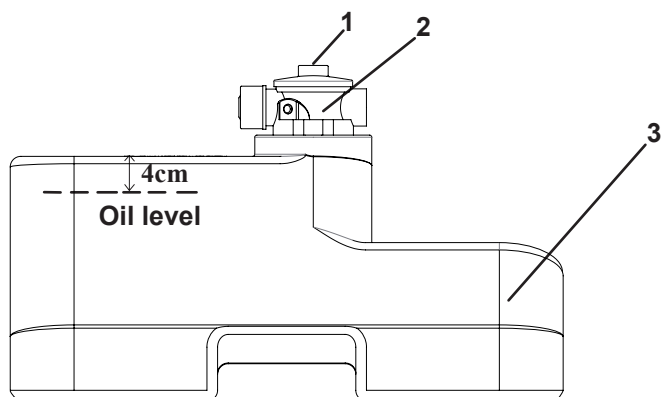

### Hydraulic Oil cooler FB 450 / FB 510

The machine is equipped with a hydraulic oil cooler. The cooler start working when the hydraulic oil reach a temperature +50 °C. Afterwards subsequently switch to and from the coolers as necessary. After shutting off the machine, the cooling fan run for a short time, which is normal.

**Note!** If the indicator light for hydraulic temperature (see the panel picture for each machine) lights red it indicates that the hydraulic oil temperature is to heat. Continue driving the machine means worse compaction capability. Stop and check the hydraulic oil cooler.

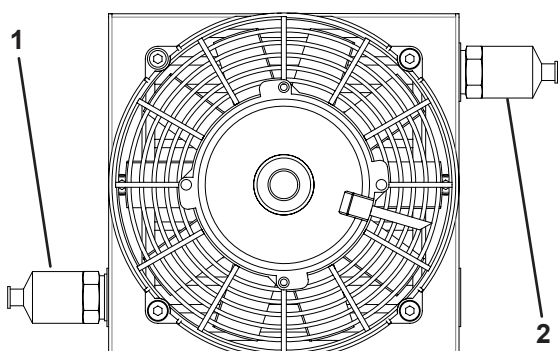

### Termostater

1. Thermostat for the hydraulic oil cooler fan
2. Thermostat for warning light high oil temperature

### V-belt Drive FB 430 / FB 500

Check the tension and condition of the V-belt regularly. Replace a damaged V-belt with the new type according to the table below

Machine type	V-belt type
FB 430	XPB 1322
FB 500	XPB 1242

### Hydraulic Oil Level Check FB 430 / FB 500

Check every day that the hydraulic connections do not leak or wear during operation. Check the oil level with the dipstick on the top of the tank. The level must be between "MIN" and "MAX". Fill up when required.

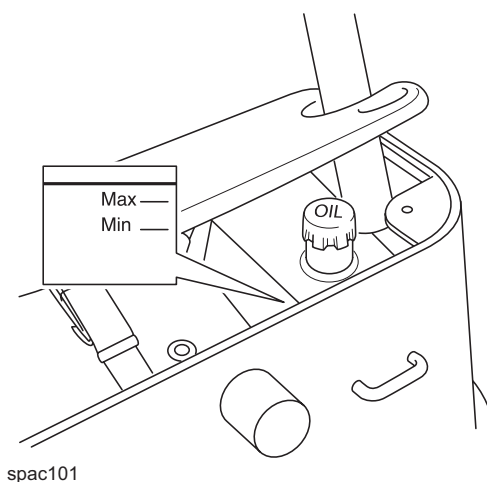

### Vibration Element

Check regularly that there is no oil leak. Seal any leaks. **Note!** Machines must never be operated if a leak is suspected. **Note!** The oil level in the vibration element is 0,5 liter.

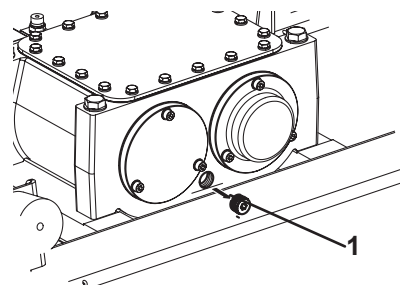

1. Drain and refill hole

### Rubber Damper

Check the condition of the rubber dampers regularly. Replace damaged dampers.

**FB 430 / FB 450**

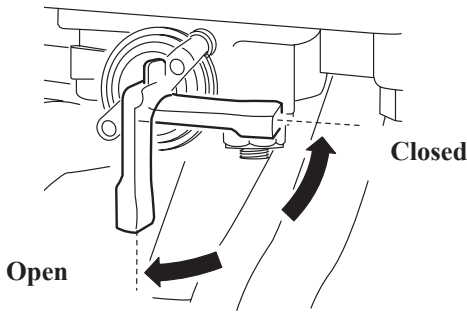

**Yanmar fuel cock**

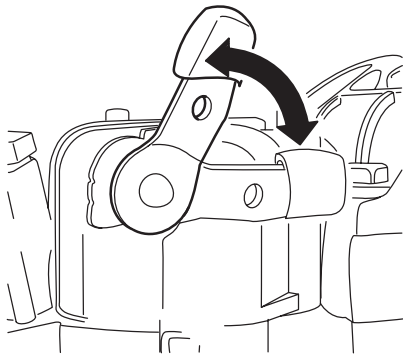

**Yanmar decompression handle**

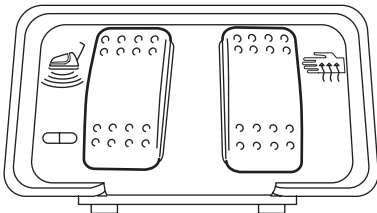

**Vibration power switch and handle heating**

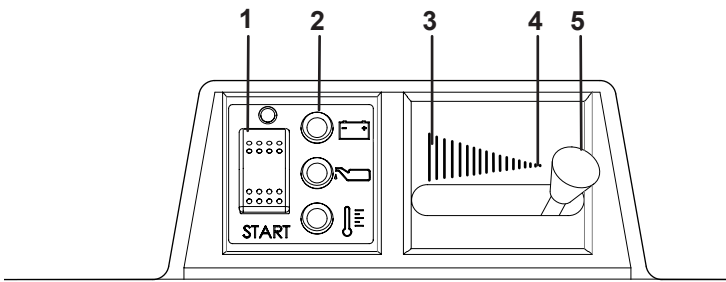

**FB 450 instrument panel with throttle lever**

1. Engine power switch
2. Control lamps for charging, oil pressure and hydraulic oil temperature
3. Full throttle position
4. Stop mode
5. Throttle

**BEFORE STARTING**

See Daily Checks on page 8.

**STARTING only FB450**

**Note! The vibration power switch on the handle must be in the position “vibration off” (red/green marking). Otherwise the machine cannot be started.**

Open the fuel cock.

Switch the throttle lever (5) to the full RPM position (3). Start the engine with the power switch (1). Place the knob in the central position and check that the charging and oil pressure lamps (2) light up. With the power switch in this position the buzzer starts to sound. Then press the power switch down (Start marking).

**Note! Never run the starter motor for longer than 10 seconds at a time. If the engine does not start, wait 15 seconds before trying to start it again.**

In very cold weather or if the battery capacity is low for a different reason, starting can be facilitated using the decompression handle in connection with the valve housing. Press the lever down and hold it down until the flywheel has reached its maximum RPM. Run the engine warm for around 5 minutes.

**STOPPING FB450**

Turn off the vibration. Switch the throttle lever (5) to idle and let the engine run for a few minutes.

Press the engine power switch (1) upwards (O marking).

Stop the engine by moving the throttle lever to the stop position (4)

**At the End of the Day**

Close the fuel cock.

**STOPPING FB430**

Press the engine power switch (1) upwards (O marking).

Stop the engine by moving the throttle lever to the stop position (4)

**At the End of the Day**

Close the fuel cock.

**FB 430 Instrument panel**

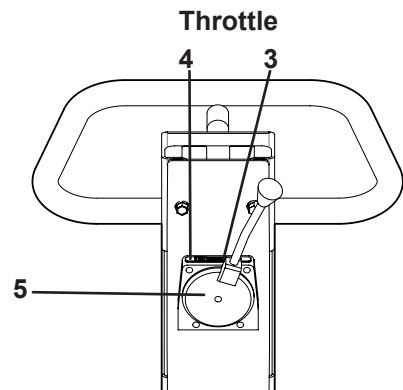
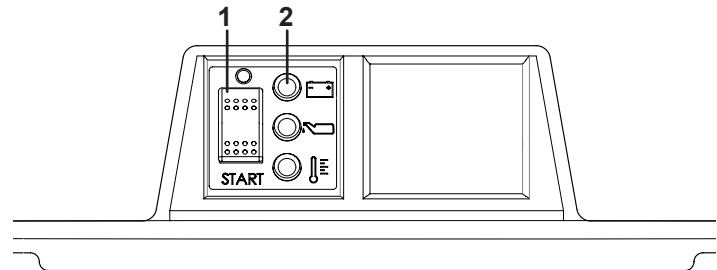

## FB 500 / FB 510

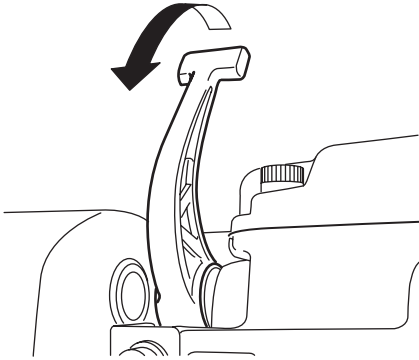

## Hatz decompression handle

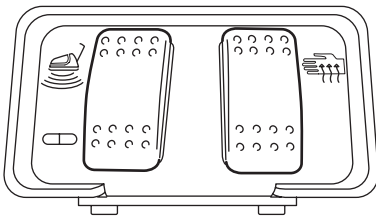

## Vibration power switch and handle heating

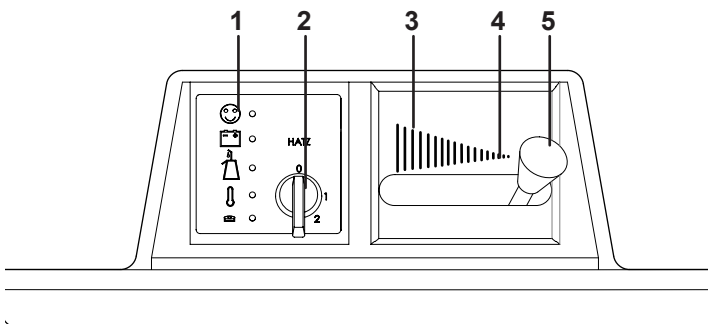

## FB 510 instrument panel with;

1. Control lamps for the engine, charging, oil pressure and hydraulic oil temperature
2. Starter key
3. Full throttle position
4. Stop mode
5. Throttle

## BEFORE STARTING

See Daily Checks on page 8.

## STARTING only FB510

**Note! The vibration power switch on the handle must be in the position “vibration off” (red/green marking). Otherwise the machine cannot be started.**

Switch the throttle lever (5) to the full RPM position (3). Insert the starter key (2) in position 0 and turn to the position 1 and check that the charging and oil pressure lamps (1) light up. With the starter key in this position 1 the buzzer starts to sound. Turn the starter key to the position 2. Release the key as soon as the engine starts. It returns to position 1 and will remain in that position during operation. Charging and oil pressure light goes off immediately after the start. Engine light (1) lights green while the engine is running.

**Note! Never run the starter motor for longer than 10 seconds at a time. If the engine does not start, wait 15 seconds before trying to start it again.**

In very cold weather or if the battery capacity is low for a different reason, starting can be facilitated using the decompression handle in connection with the valve housing. Press the lever down and hold it down until the flywheel has reached its maximum RPM. Run the engine warm for around 5 minutes.

## STOPPING FB510

Turn off the vibration. Switch the throttle lever (5) to idle and let the engine run for a few minutes.

Turn the starter key to the position 0.

Stop the engine by moving the throttle lever to the stop position (4)

## STOPPING FB500

Turn the starter key to the position 0.

Stop the engine by moving the throttle lever to the stop position (4)

## FB 500 Instrument panel

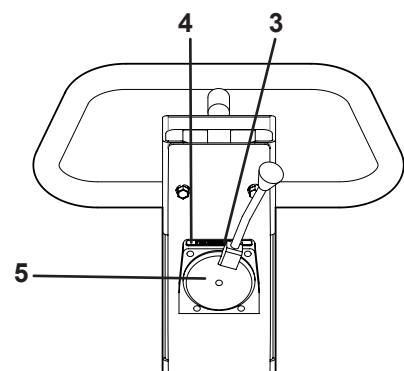
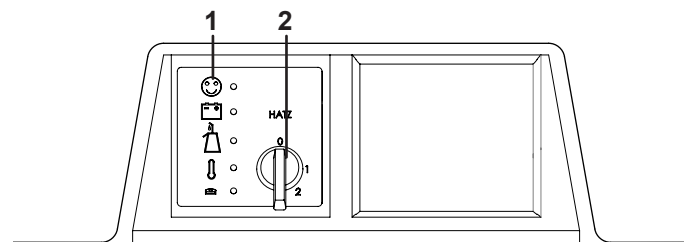

## OPERATING INSTRUCTIONS

The vibrator is started and stopped with the power switch on the handle.

When the control hoop on the handle is moved backwards, the machine reverses and when the hoop is moved forwards, the machine moves forwards. The speed is controlled by how long the control hoop is activated.

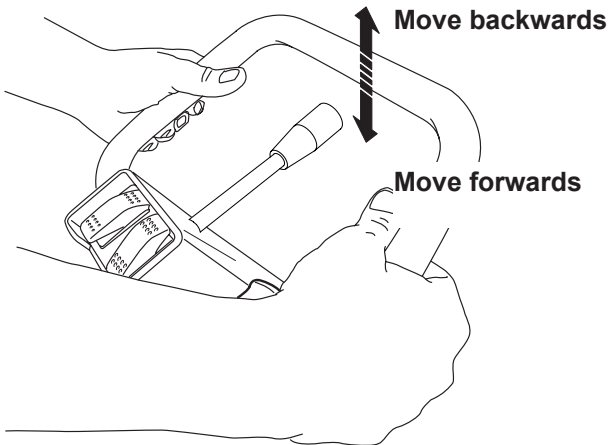

The machine is only designed to be used outdoors. Work with the machine in daylight or other adequate lighting. Ballast must be wetted or naturally damp. All other use is discouraged.

Note! When moving up a slope, the machine should be reversed.

The machine may not incline more than 20° when in use or parked.

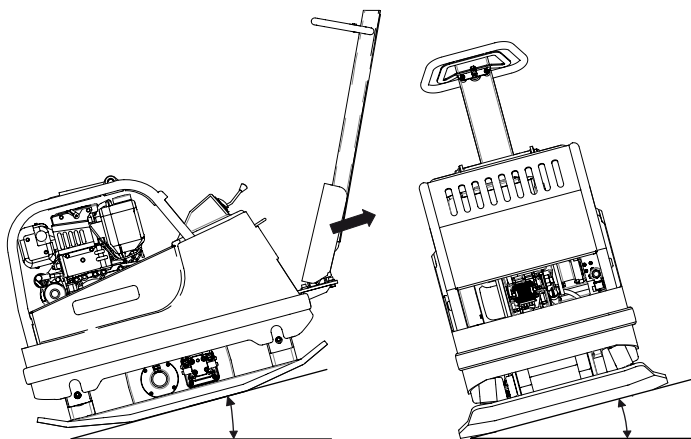

### Handle Heating

For increased comfort, the machine has an electrically heated handle. The handle heating is activated with the power switch on the handle and can only be used when the vibrator is connected, which prevents the heating coil from discharging the battery when the machine is not being used.

## TRANSPORTATION

The machine is fitted with a lift eye that can be placed on the hood when not in use.

NOTE! Use only safety frame lifting point (1) to lift the machine.

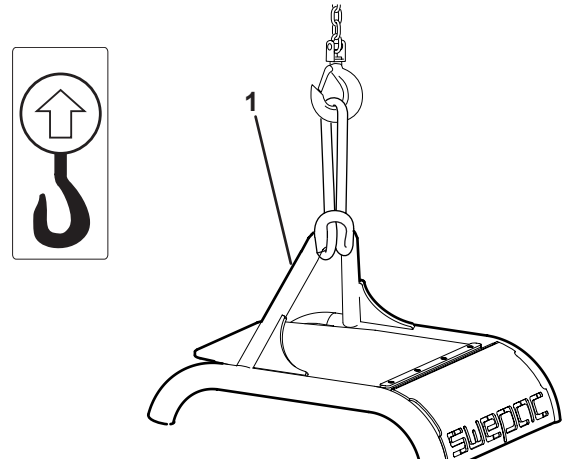

Check before lifting that the lifting eye and its mounting on the machine are undamaged. Check also that the base plate's rubber dampers are undamaged and firmly attached. For transportation by vehicle, the handle must be folded forwards and locked with the transport locking device. The machine must then be secured with, for example, approved straps. Note! Secure it by the base plate and not the rubber-cushioned upper part.

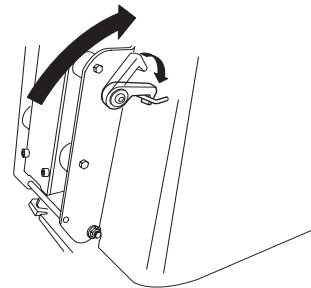

### Transport locking

Secure the machine with straps according to illustration during transportation

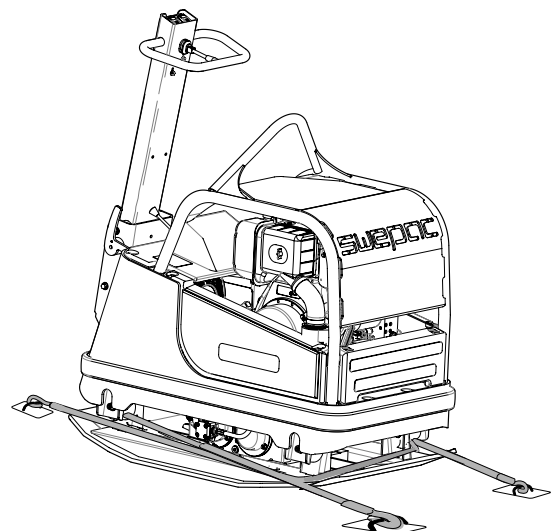



## Belt tension / replacement of belt refers to FB430 och FB500

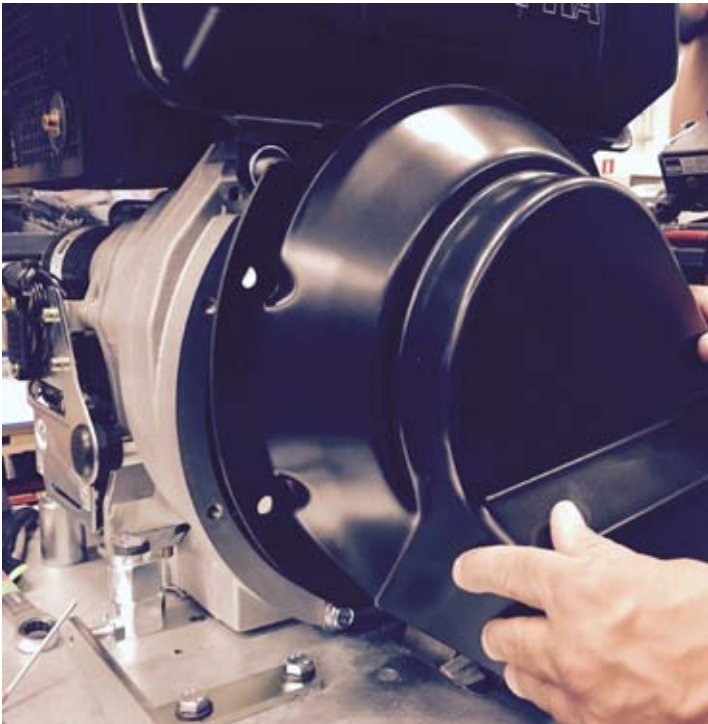

**Loosen the belt cover**

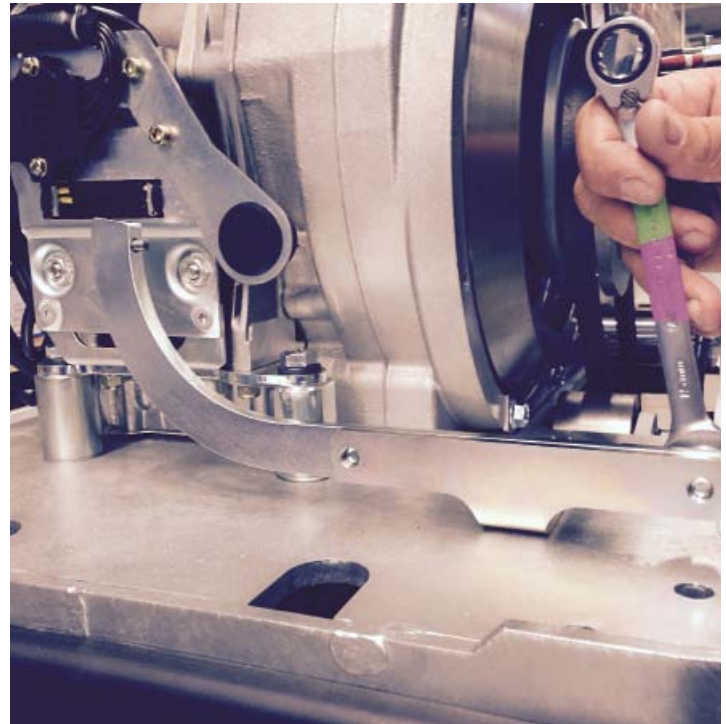

**Loosen the hook wrench**



**Loosen the three set screws (as shown)**

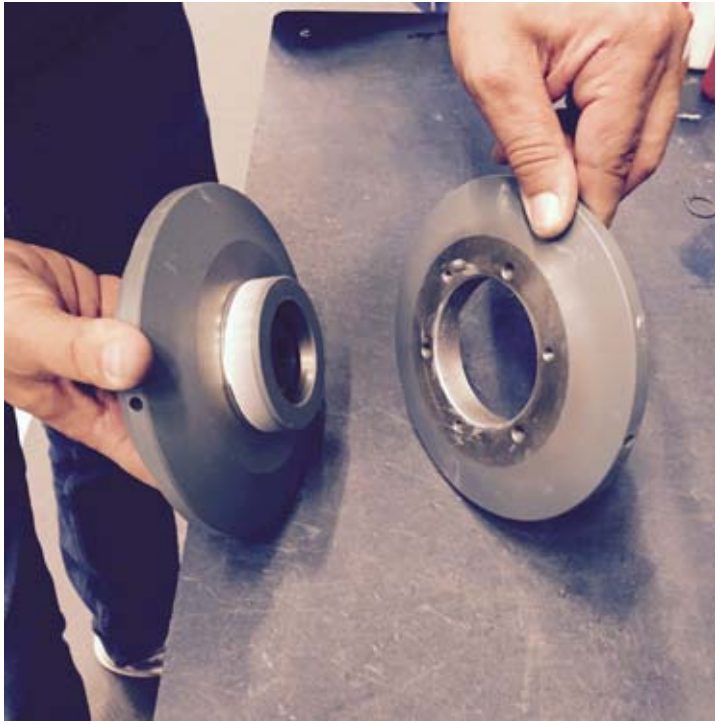
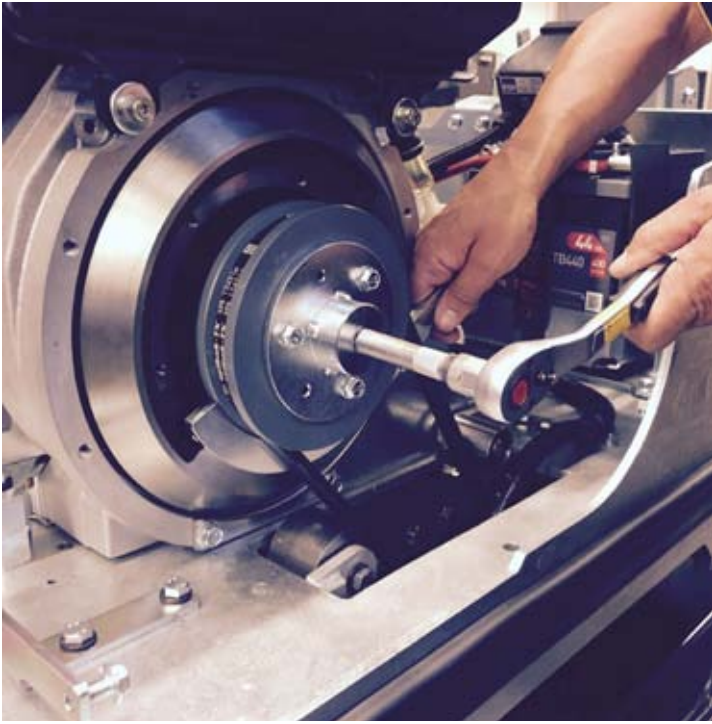

To replace the belt, follow instructions on the picture and turn the outer part of the centrifugal clutch counterclockwise.

The centrifugal clutch is divisible

Hold with hook wrench according to the image and in order to tighten the belt, rotate the outer part of the centrifugal clutch clockwise

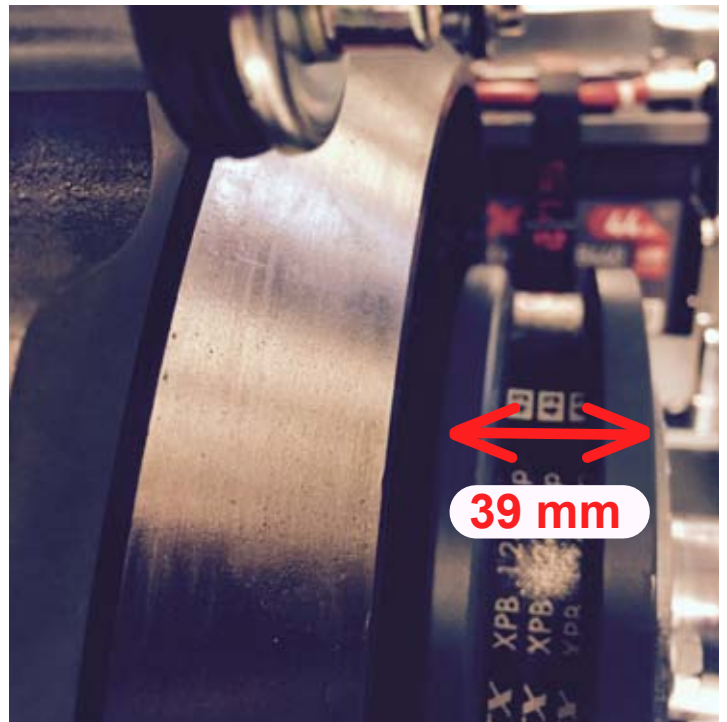

Reassemble in reverse order.

**NB!** Do not forget to tighten the three set screws

## MEASUREMENT AND ADJUSTMENT OF HYDRAULIC OIL PRESSURE FB450 / FB510

A clear picture of the hydraulic system's state or an indication of the cause of malfunction is obtained by simultaneously measuring the system pressure, the drive motor speed and vibration frequency. The soil compactor shall be in operation and maintain normal operating temperature. Hydraulic oil temperature 50-70 ° C.

The hydraulic system's maximum pressure is preset upon delivery. Default pressure is 200 bar and can be measured in the starting moment when the oil in the hydraulic system is cold.

When the soil compactor has reached normal operating temperature, the pressure must be 30-50 bar lower than the system's maximum pressure.

The pressure increases proportionally with increasing load, eg if the soil compactor is run at low speed or even standing still during operation. When maximum pressure is reached, vibration speed is reduced.

Measurement of drive motor speed and vibration frequency is performed with a strobe with graduated scale. The hydraulic pressure is measured with a pressure gauge with connection for gauge ports on the valve block, see picture. The hydraulic pressure for the conversion should be between 20-22 bar and is measured with a pressure gauge with connection for gauge ports on the distribution block, see picture. Strobe light and gauge can be ordered at SWEpac.

Engine speed .....3000 rpm loaded Yanmar / 2900 rpm loaded Hatz

Vibration frequency at hydraulic oil temp. ca. 50 ° C ..... 70-72 Hz; 4200-4320 rpm

Normal running pressure hydraulic oil temp. ca. 50 ° C ..... 150-170 bar

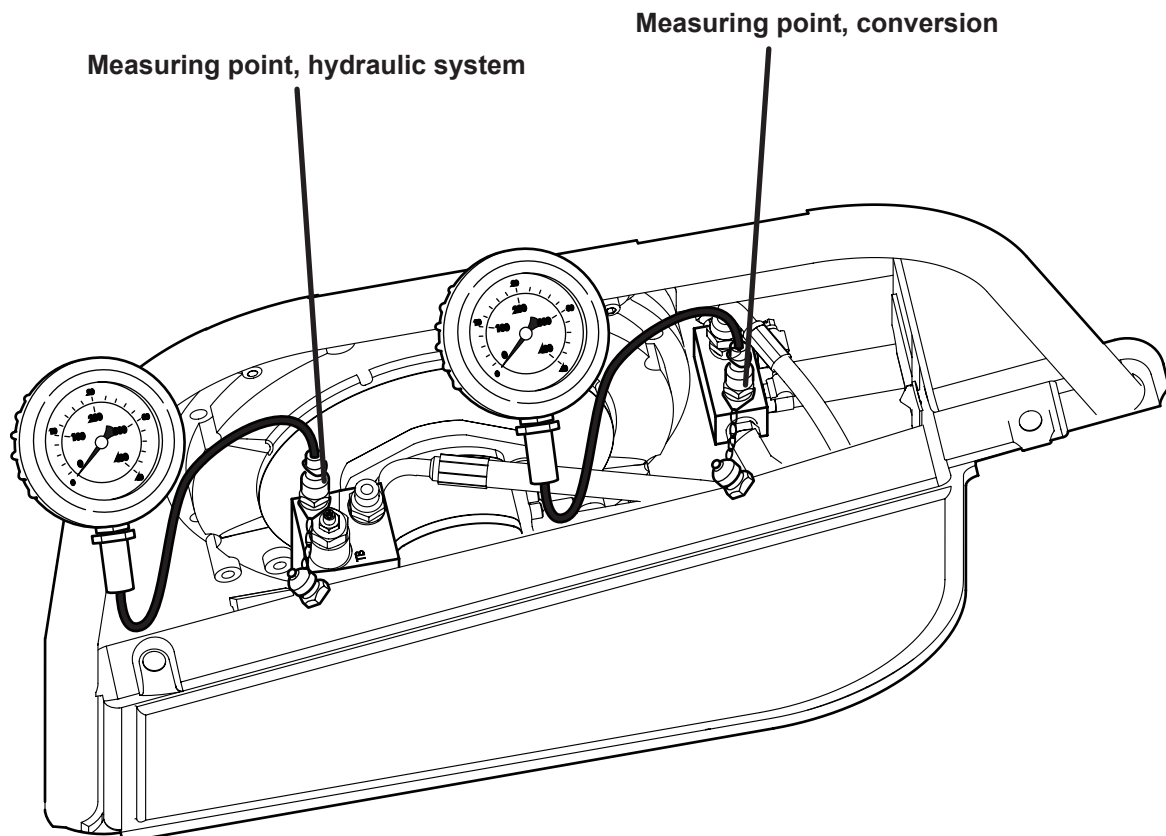

## Hydraulic diagram FB450 / FB510

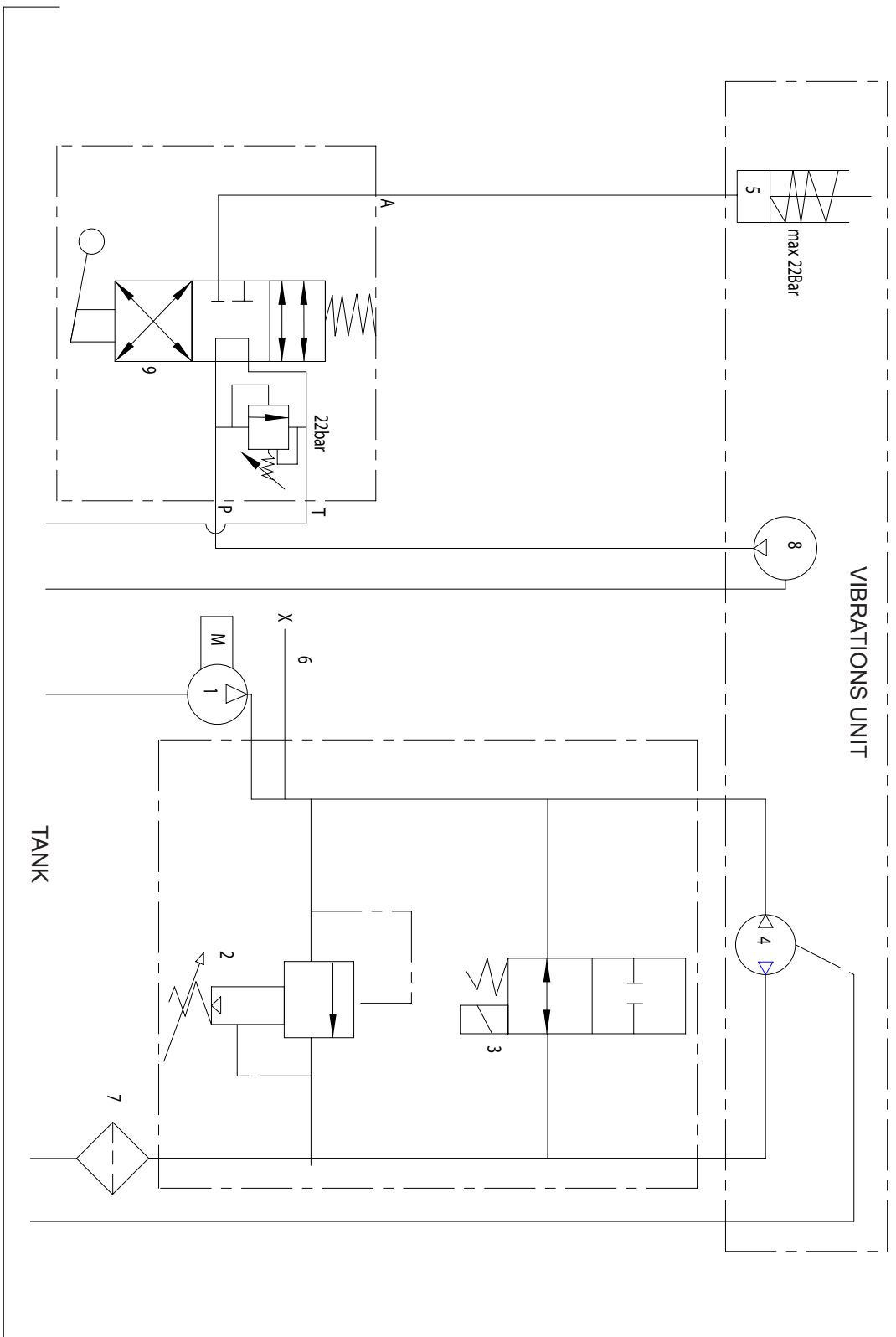

- 1) Hydraulic pump 6.14 cc 3000 rpm (Yanmar) 6.45 cc 2900 rpm (Hatz)
- 2) Pressure relief valve max 200 Bar
- 3) Solenoid valve vibration On / Off
- 4) Hydraulic Motor 4.09 4300rpm
- 5) Hydraulic cylinder Front / Back
- 6) Measuring point
- 7) Return oil filter
- 8) Hydraulic pump conversion 0.75 cc 4300 rpm
- 9) Valve block conversion



## Measurement of the conversion hydraulic oil pressure FB430 / FB500

In order to measure hydraulic oil pressure for the conversion, the cover plate on the rear of the handle must be removed.

The hydraulic pressure for the conversion should be between 20-22 bar and is measured with a pressure gauge with connection for gauge ports on the valve block, see picture. The measuring point is plugged from the factory. In order to measure the hydraulic oil pressure for the conversion, the plug must be unscrewed and a measuring point put there instead. Pressure gauge and measuring point (101027 measuring point) can be ordered from SWEPAC.

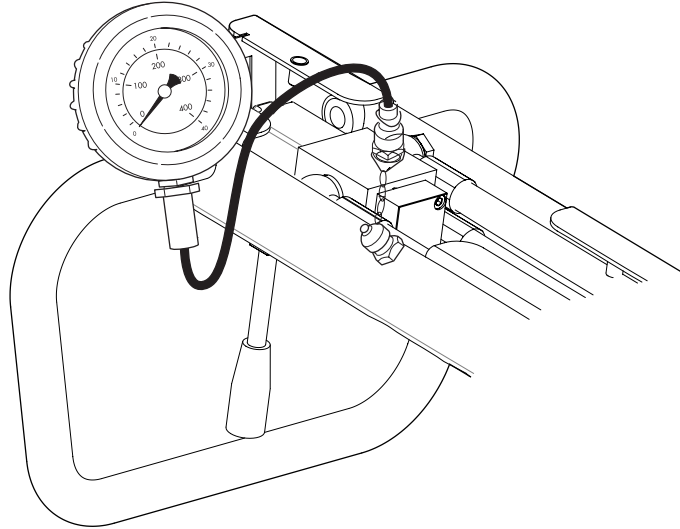

## Hydraulic diagram FB430 / FB500

### VIBRATIONS UNIT

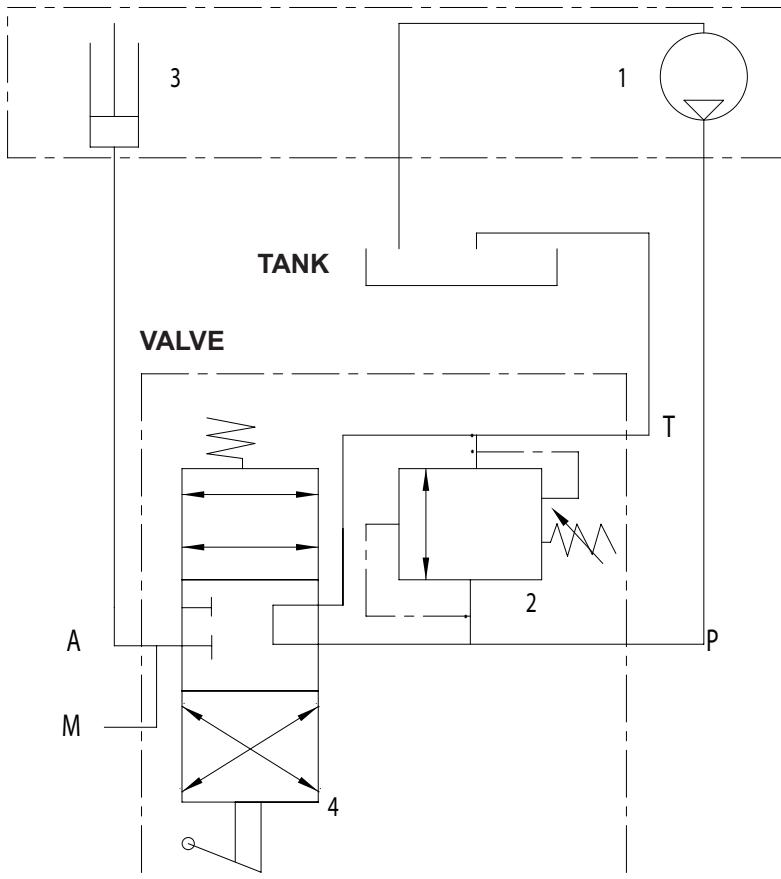

- 1) Hydraulic pump conversion
- 2) Pressure relief valve 20 Bar
- 3) Hydraulic cylinder Front / Back
- 4) Manually operated valve block conversion

## ACCESSORIES

### Swepac Compaction Indicator (SCI)

SCI consists of an accelerometer sensor mounted on the right side of the vibration element, and a display unit provided with LEDs that light up as the compaction progresses. The sensor and the display are connected with a cable. The display is also powered by a separate cable.

#### The Principle:

The base plate motion characteristics vary with increasing or decreasing soil compaction. The sensor continuously measures the variations in the base plate movement. The data from this is analyzed in the processor, which in turn sends signals to the display to visualize this with the lights.

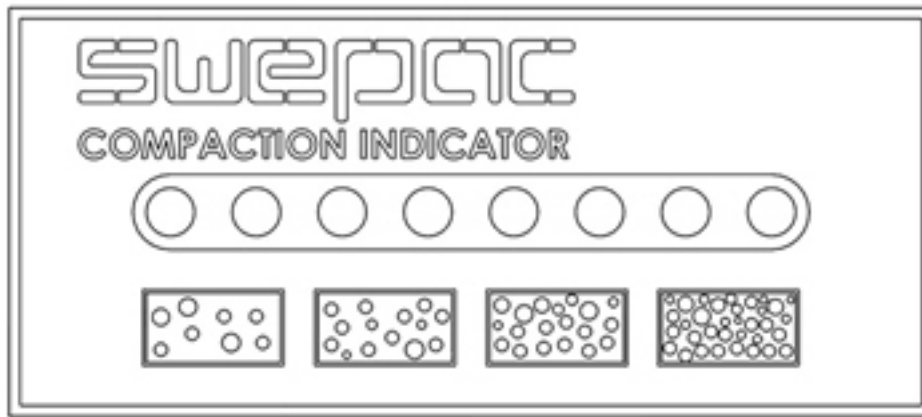

#### When starting:

When starting with the ignition key, the yellow LEDs 1, 3, 5, 7 will flash at first and thereafter the LEDs 2, 4, 6, 8 will flash.

The diodes remain lit until communication with the sensor is operating. This normally takes a second. If the power supply is interrupted or communication stops for more than 20 seconds, the flashing LED pattern returns until the communication works again. Thereafter, all the LEDs will be turned off and the indicator is ready for operation.

After starting the machine or after onset of vibrations (FB450 and FB510), it will take 2-3 seconds before the indicator starts to record the movements of the base plate. The reason is that the sensor does not start measuring until the vibrator generates the correct frequency on the base plate. The display will not indicate anything if the speed of the engine is reduced since the vibrator then is slower and the base plate does not reach the right frequency.

No calibration of the indicator is required when starting the machine.

#### During use:

When operating, the LED lights will illuminate from left to right. The number of lights that are lit during operation is dependent on soil quality and characteristics. When the number of lit lights do not increase, the ground will not be compacted further at other crossings. It therefore means that all lamps will not necessarily be lit during the compaction work.

The lights indicate the surface's compression status during the work. If no more lights are lit, the maximum compaction of the substrate is achieved. Swepac Compaction Indicator is no substitute for the conventional assay of the degree of compaction but is used to provide the operator with useful information such as finding areas that are not compacted or to avoid overcompacting with the risk of damage to the machine.



## EC-declaration of conformity

### Manufacturer

**Swepac AB  
Blockvägen 3  
34132 Ljungby**

1. Category: Vibratory plate

2. Type: FB430.....7kW  
FB450.....7kW  
FB500.....7,5kW  
FB510.....7,5kW

3. Engine power: FB430.....7kW  
FB450.....7kW  
FB500.....7,5kW  
FB510.....7,5kW

The product complies with the following directives:

2006 / 42 / EG

2000 / 14 / EG

2004 / 108 / EG

EN 500-1

EN 500-4

Technical documentation held by:

Swepac AB, Blockvägen 3 SE-34132 Ljungby  
Tomas Johansson / Product Engineer

**SWEPAC**

**SWEPAC AB**

Address **Blockvägen 3, 341 32 Ljungby, Sweden**, tel. +46 (0)372-156 00, fax +46 (0)372-837 41, E-mail [mail@swepac.se](mailto:mail@swepac.se),  
Internet [www.swepac.se](http://www.swepac.se)